



OWNER'S MANUAL

CURVED STAIRLIFT MODEL L - 06



CONTENTS

1. SUPPLIER DETAILS	pag. 2
2. PURCHASE INFORMATION FOR BUYERS.....	pag. 2
3. FEATURES	pag. 2
3.1 GENERAL DESCRIPTION	
3.2 TECHNICAL DATA	
3.3 ENVIRONMENTAL INFLUENCE	
4. USE	pag. 6
4.1 ELEMENTS OF USE	
4.2 PREVENTIVE MEASURES BEFORE USE	
4.3 PROHIBITIONS	
5. MAINTENANCE	pag. 15
5.1 BY THE USER	
5.2. BY AUTHORIZED COMPANIES	
5.3 MAINTENANCE LIST	
6. WARRANTY AND SERVICE	pag. 16
6.1 WARRANTY	
6.2 SERVICE	

1. SUPPLIER DETAILS

If you have any questions regarding the operation or maintenance of your stair lift, please contact your supplier by phone or in writing.

Supplier name:

Address:.....

Phone no.:.....

E-mail:.....

2. PURCHASE INFORMATION FOR BUYERS

If maintenance or repairs under guarantee are needed, your supplier will need the following information:

Client name:

Address:.....

Phone no.:.....

Date of purchase:

Stair lift serial no.:

3. FEATURES

3.1 GENERAL DESCRIPTION

The L-06 stair lift was designed to help adults with locomotor disabilities or the senior citizen have access to on two or even three levels inside their home or building. It is a complex lift that can be installed both on the inside and outside of the stairs. To occupy as little space in the parking area, it can be folded. The distance occupied by the rail from the wall is smaller than for most lifts. Also, the angle at which the lift ascends is higher than for most other lifts. The concept, design and execution of the stair lift at exceptional efficiency allows its travel on two or three levels. To call the stair lift from the parking area you will use the remote control.

After the check, trial, and endurance runs, the lifetime of this lift was determined to be of at least 15 years, when used between 800 and 1,500 cycles per year and properly maintained through periodic revisions.

For your safety, this lift type was equipped with all necessary guards and some features (e.g., electrical rotation of the seat).

The L-06 stair lift travels on a track consisting of two parallel pipes with different diameters arranged one above the other for optimal retrieval of loads, the two pipes being rigidly interconnected by means of mountings that connect them with the steps via some foot supports fastened with screws to the track mountings and fastened to the steps with screws –fig. 1.

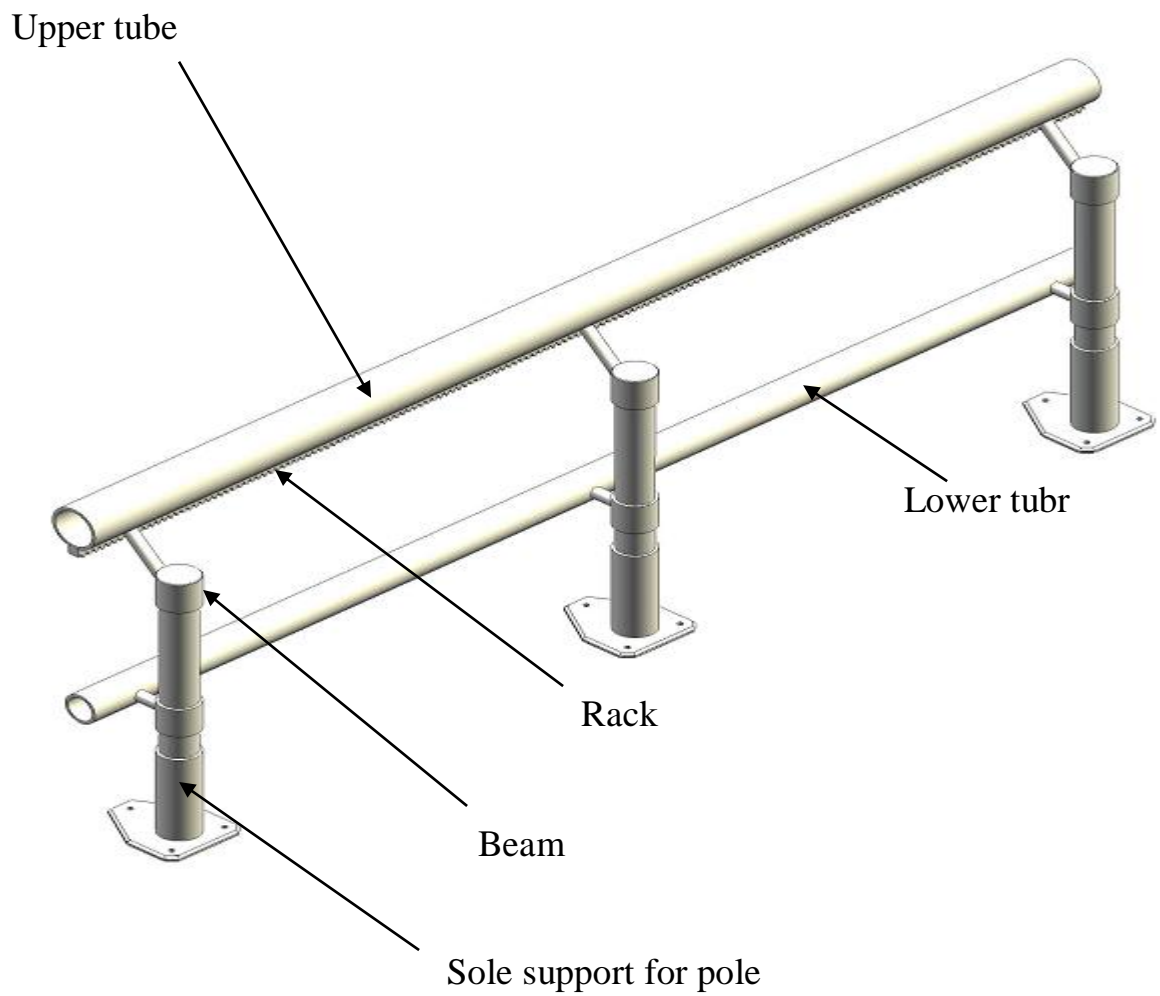

Fig. 1

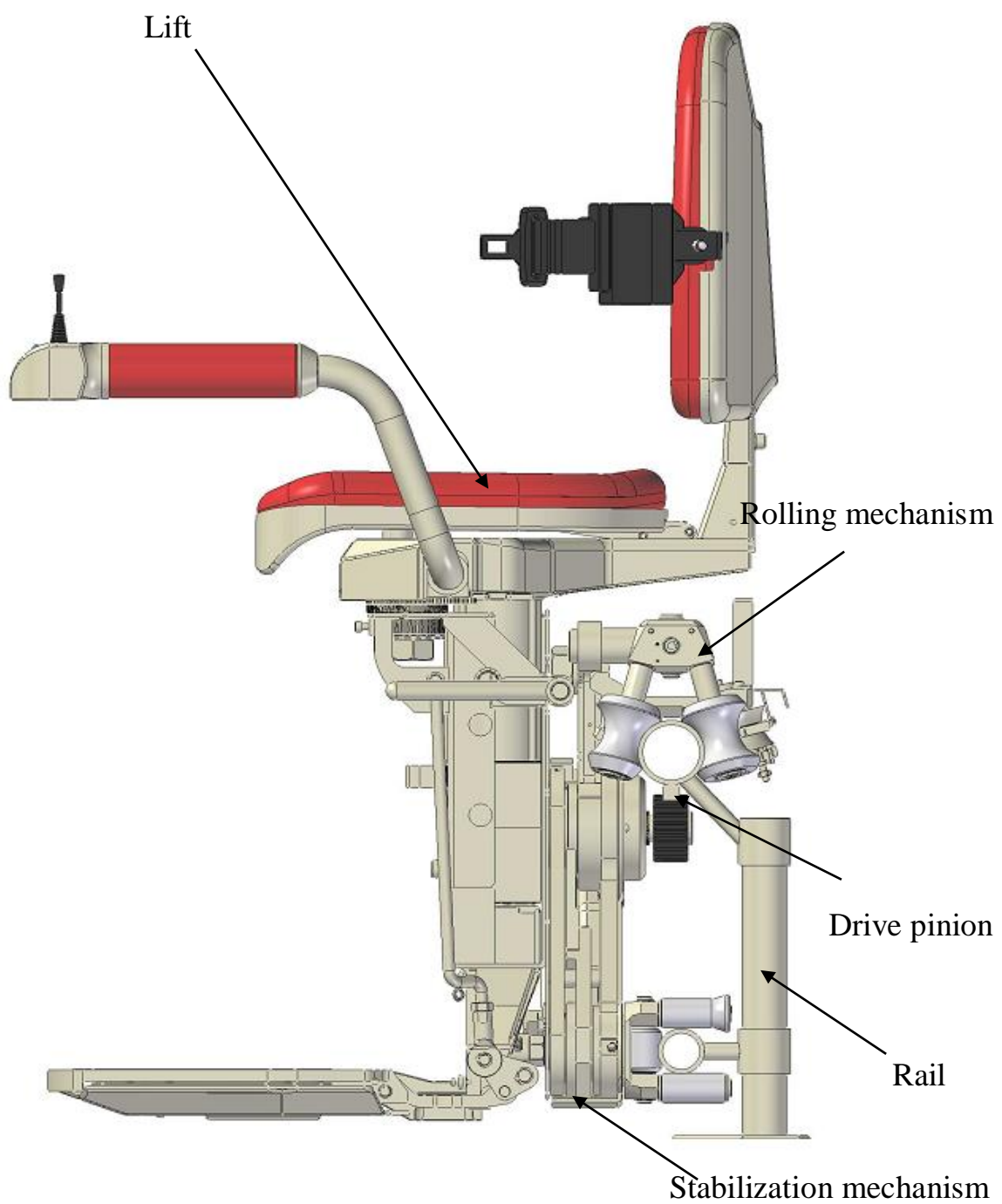

Fig. 2

3.2 TECHNICAL DATA

- Rated capacity – 275 lbs (125 kg).
- Travel speed – programmable up to a max. val. of 0.32 ft/s (0.1 m/s) \pm 10 %
- The height measured from the top of the leg support against the stairs along the travel path is ca. 19 in. (500 mm).
- The inclination angle of the track measured against the horizontal:
 - standard 0-45°

In exceptional cases, only following additional measures of protection and the written consent of the client, the lift can be used in the following conditions:

- ascent angle – max. 58°
- max. load 150 kg.
- distance from the foot rest against the stairs of max. 600 mm
- battery run time is 2 hours without charging, limited at 4 starts per hour and a path length of 6m at an angle of ascent of 50°
- No. of starts allowed per hour is 8 starts at a room temp. of 20°

The remote control allows you to set a unique code to prevent interference if using other transmitters nearby.

The control joystick can be installed in the right arm or left arm.

3.3 ENVIRONMENTAL INFLUENCE

This model has no negative influence on the environment, produces no emissions, vibrations, noise, or anything else that could adversely impact the user.

The only thing to be observed is that, after changing the batteries (after a period of about 2-4 years of use), these should be taken to and recycled at the proper disposal place within your town/city for batteries

+

4. USE

4.1 HOW TO USE

Calling the lift from/to the parking area is made with the remote control in fig. 3, by pressing one of the two keys labeled with arrows.

Keep the button pressed without worrying because the lift will slow down and stop automatically when it reaches the end of the track where you are.

We do not recommend that you press + release the remote button when it reaches the end of the track because the lift will stop.



Fig. 3



Before using the remote, always make sure that no one is getting on or off the lift at that time. The remote control can also move the lift even if it is not in your line of sight.

To occupy less space, the lift can be folded in the parking area, as shown in fig. no. 4

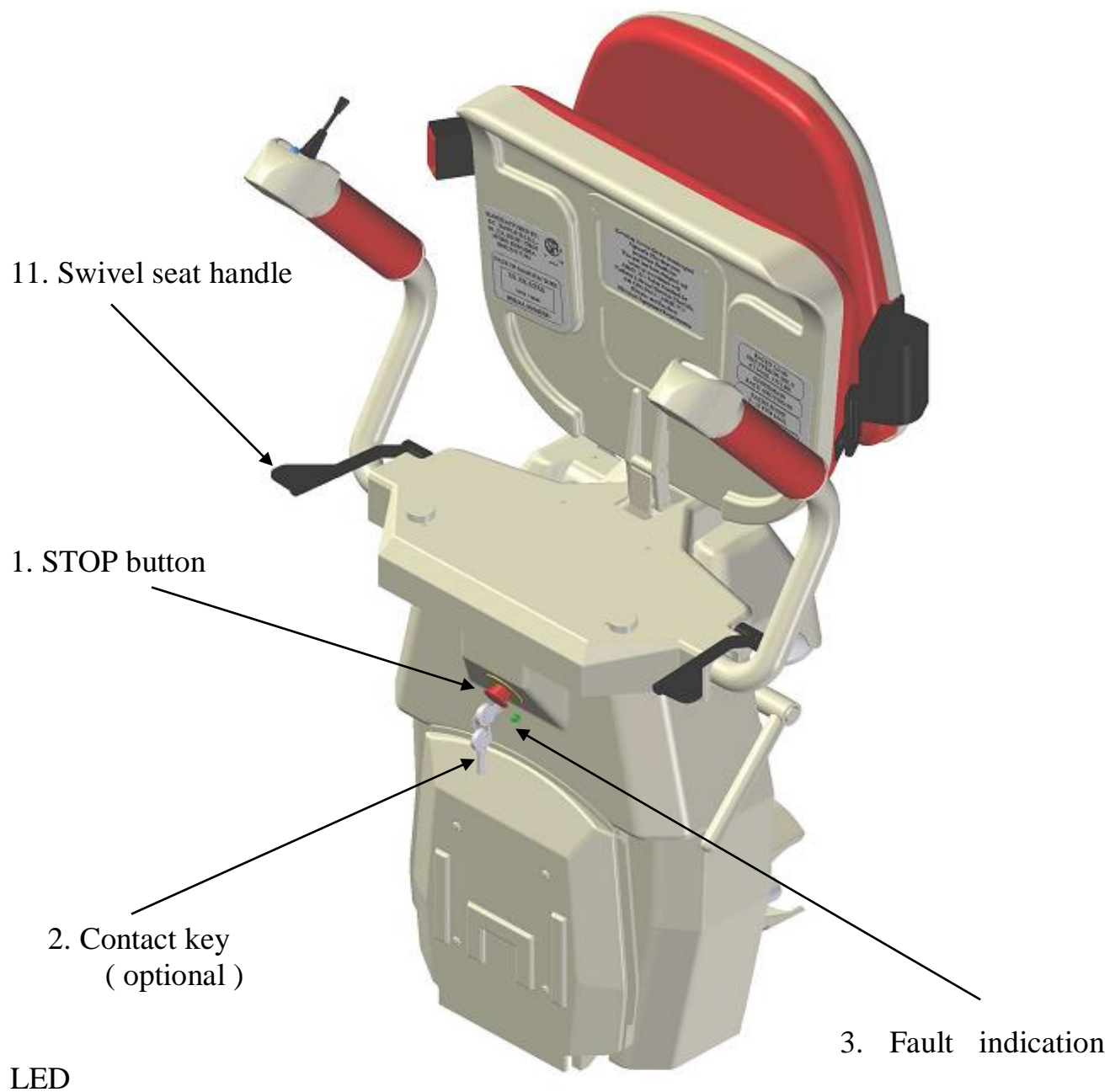

Fig. No. 4

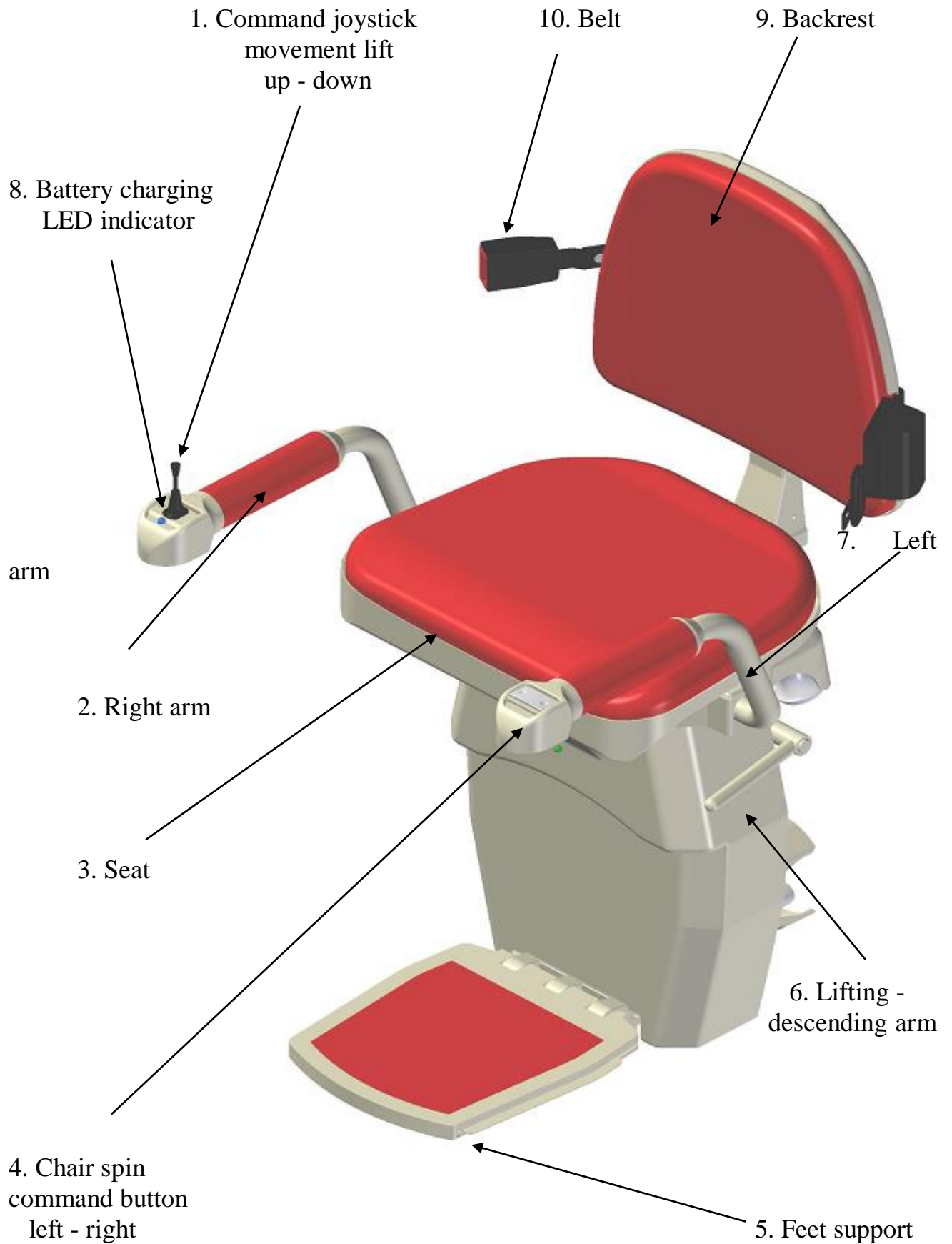

Fig. 5

To put the lift into operation, proceed as follows:

- bring down the arms (2) and (7) from the vertical position, as shown in fig. 4, to a horizontal position, as shown in fig. 5.

- the same applies to the seat (3)

- by lifting the handle (6), you can also tilt the foot rest (5) from a folded position fig. 2 to a use position fig. 5; after that, you can get on the lift. Starting and moving the lift is made by moving the joystick (1) fig. 5, as follows:

- to move to the right, move the joystick to the right and hold.

- to move to the left, move the joystick to the left and hold

- we do not recommend that you interrupt the command unless in case of obstacles

- to stop the lift at either end of the track, the control joystick must remain actuated until the lift reaches the charging contacts and stops on its own, followed by the blue LED (8) on the joystick arm lighting up, this indicating that the battery is charging from the power supply

- if the lift is stopped on the track outside the charging elements, it will beep to warn that the battery is not charging, and therefore that it must be moved so that the lift may reach the charging contacts

- when the travel ends and the top of the track is reached, the seat (3) with backrest and arms (2) and (7) fig. 5 are rotated to max. 90° to facilitate the user to get on and off the seat. The standard stair lift is equipped with manual swivel seat function. Next are the steps for using this function:

- lift one of the handles (11) and slowly rotate the seat. After the seat starts to rotate release the handle (11) and continue the rotation in the direction you have to get of the lift. The rotation of the seat stops at 75° - fig no 5.1. if you want the seat to rotate to 90°, lift the handle (11) again and turn more in the same direction until the seat reaches 90°.

- to get back to the normal running position lift again the handle (11) and move in the opposite direction as described above until the seat reaches the normal running position.

Optionally, the stair lift can be equipped with electrical swivel seat function.

This movement is controlled by button (4) fig. 5, as follows:

- actuate the button in the right for right lifts or in the left for left lifts, and rotating will occur as long as the button is pressed down, automatically stopping at a max. angle of rotation of 90°

- optionally, the rotation angle of the seat can also be programmed by default at another intermediate value. Value which should be communicated at the time when the lift is ordered

- to return the backrest and seat in normal travel position fig. 6, press the same button on the reverse side.

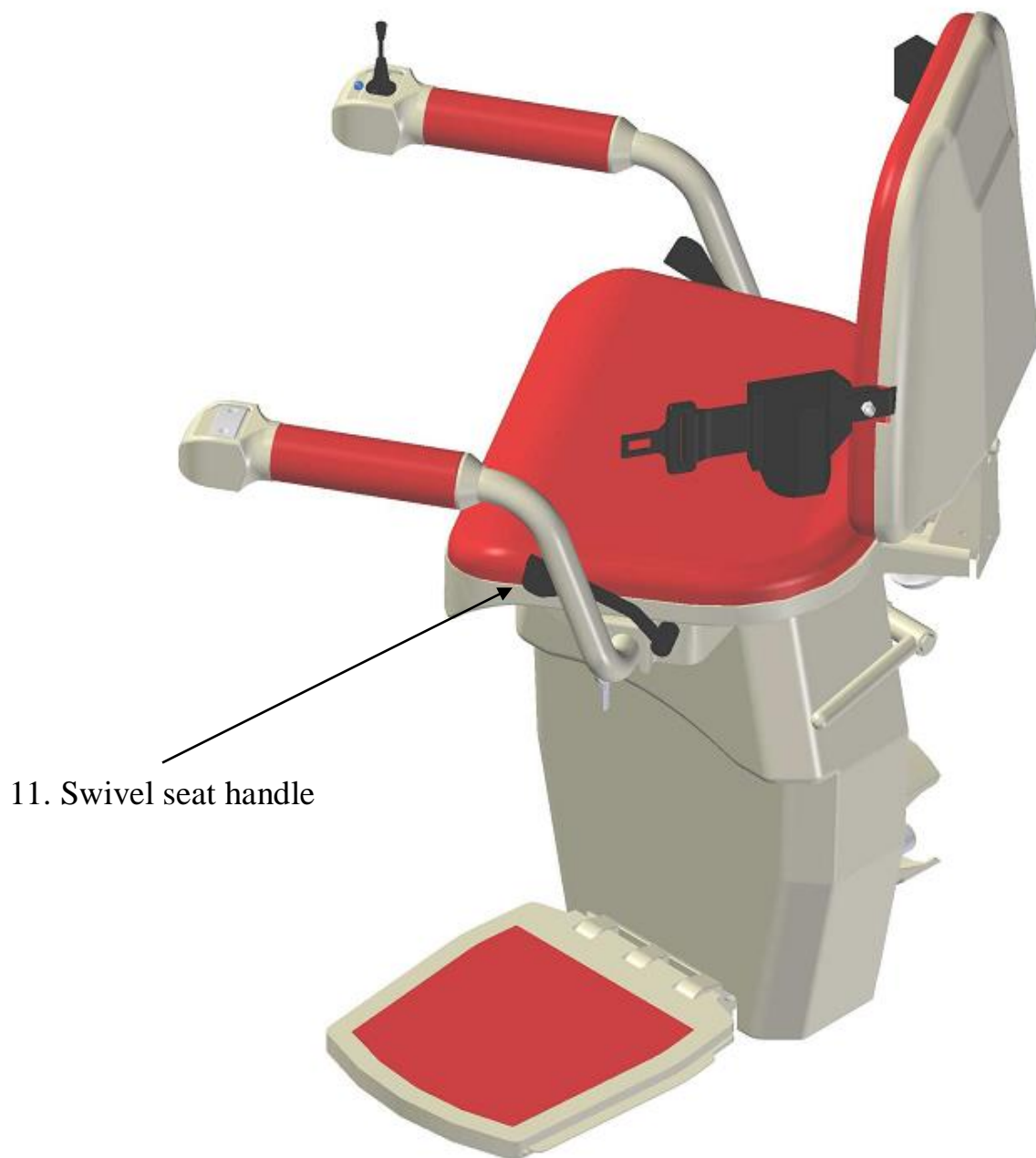

11. Swivel seat handle

Fig. 5.1



The lift does not move unless the seat is in the correct travel position.



Correct position

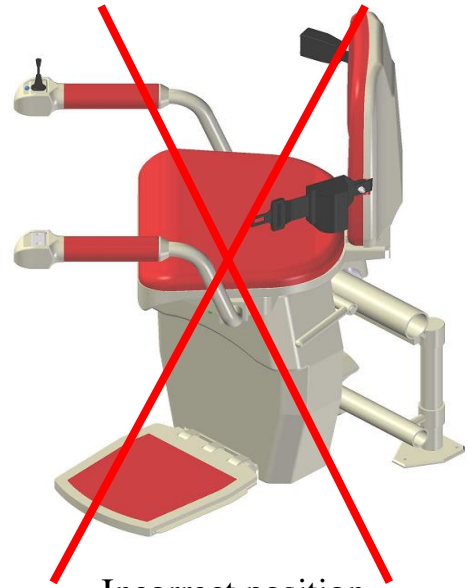

Incorrect position

Fig. 6

- after the travel has ended, get off the lift and folds as follows:
- lift the seat (3), arms (2) and (7), press the handle (6) fig. 5, then, using the remote, send the lift in the parking area

The LED (3) fig. 2 signals using a certain code (flashes) any possible malfunction (e.g.: the lift reached an obstacle without you seeing it, or the seat (3) fig. 3 is not in the correct travel position, and when any other protection sensor is activated).

Communicating this code (how many times the LED flashes on and off) to the authorized lift maintenance company, interventions can be performed more quickly and effectively to remedy the situation.

The LED illuminates when the switch key (2) fig. 2 is inserted, and stays on all the time the lift is on.



IF YOU SWITCH ON AND THE LED DOES NOT LIGHT, THIS MEANS THAT THE BATTERIES ARE DISCHARGED, SO MAKE SURE THAT YOU HAVE NOT ACCIDENTALLY UNPLUGGED THE BATTERY CHARGER.

In order to avoid unpleasant accidents, the lift is equipped with obstacle sensors for both track and stairs. When such a sensor actuates (when the lift hits an obstacle on the stairs or track), the travel of the lift in that direction stops, allowing the movement of the lift in the reverse direction to remove the obstacle. The lift areas provided with obstacle sensors are shown in fig. 7.

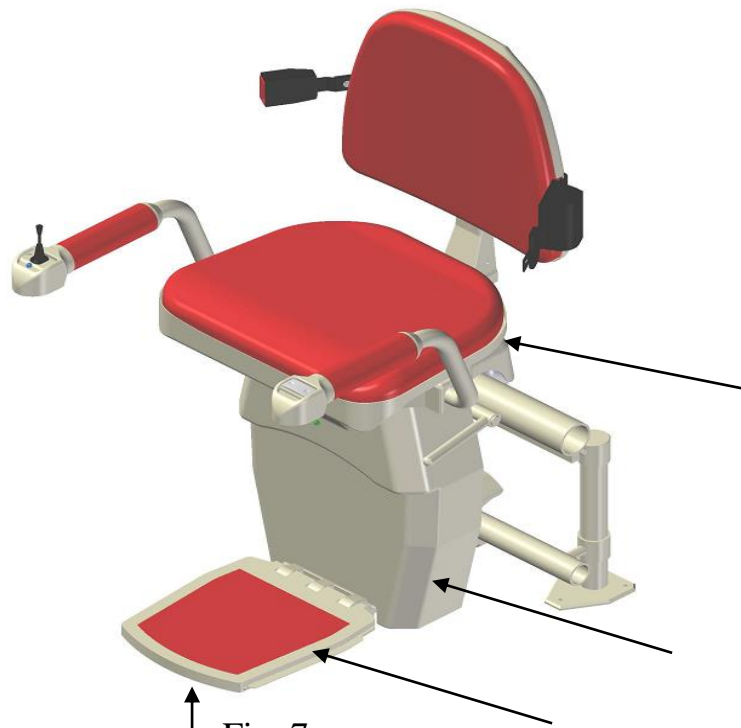
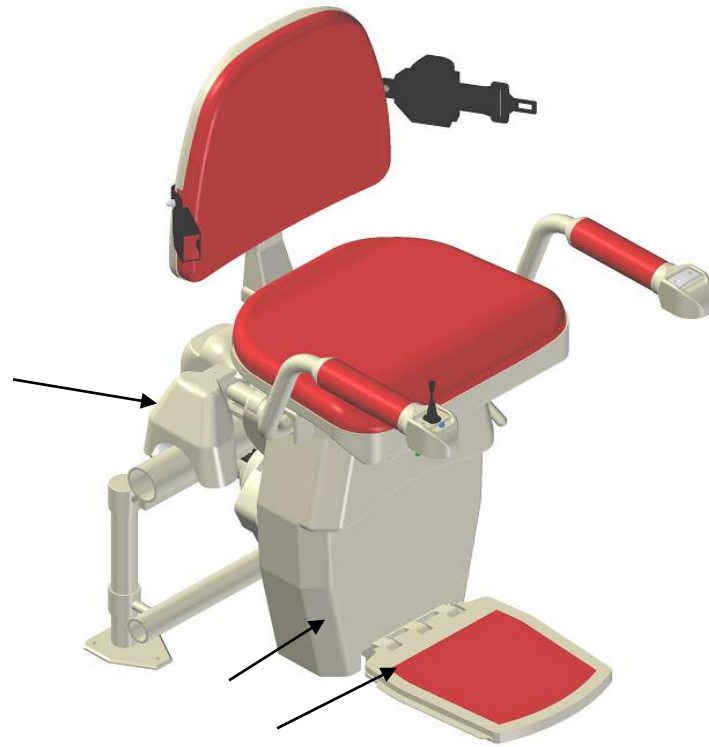

Fig. 7

Information on the characteristics of the lift, date of manufacture, serial number and manufacturer's name can be seen on the tags mounted visibly on the lift, as follows:



Conforms to Std. ASME A18.1, ASME A17.5

Certified to CSA Std. CSA B355, CSA B613, CSA B44.1

MANUFACTURED BY: S.C. HAWLE H S.R.L

No. 224, BILED, TIMIS 307060, ROMANIA

0040256377385

Model L-06

DATE OF MANUFACTURE:

ZZ.MM.YYYY

XXXX/XXXX

SERIAL NUMBER:

**RATED LOAD
ONE PERSON ONLY
AT MAX. 350 LBS.**

**SUSPENSION
RACK AND PINION**

**RATED SPEED
0 - 20 FPM MAX.**

**ELECTRICAL RATING
INPUT: 24 VDC, 2A Max.
OUTPUT: 24 VDC, 14.5A**

**Elevating Device for the Handicapped
Appareils Elevateur pour
personnes Handicape
This unit has been designed and
tested in accordance with
ASME 18.1 Safety Standard for
Platform Lifts and Stairway Chairlifts,
and CSA B44.1 / ASME 17.5
Elevator and Escalator
Electrical Equipment Requirements**

4.2 PREVENTIVE MEASURES BEFORE USE

- check that both the seat and arms are used in the correct travel position according to fig. 6.
- before use, check that there are no obstacles on the rail or on the lift's travel area.
- use the lift only after removing such obstacles.
- make sure that no clothes are hanging that can be caught by the lift.
- keep your legs only on the foot support and do not stretch your legs over it.
- while moving, hold hands on the lift arms.
- always use the seat belt when you move using the stair lift
- sit correctly on the lift, do not lean back or forward.
- after use, remove the switch key and keep it in a safe place so as to prevent the lift from being used by children or other unauthorized persons.
- check that the battery charging source is not disconnected and that the battery LED shows the stair lift is charging



SET THE ON/OFF SWITCH ON THE FRONT COVER OF THE STAIR LIFT TO POSITION „ON” TO ALLOW THE BATTERIES TO BE CHARGED.

If the switch is on „OFF” position, the batteries will not charge!

4.3 PROHIBITIONS

The following are prohibited:

- several people getting on the lift – the lift is designed to safely transport one person
- traveling while standing on the lift
- using the lift in case of fire
- placing the lift in places with high humidity or where it may come in contact with water
- spraying it with liquid
- dirtying or lubricating the controls
- transport of flammable materials
- transport of objects
- exceeding the maximum load capacity
- washing or cleaning of the track

5. MAINTENANCE

5.1 BY THE USER

The only thing the user must do is to keep the lift and rail clean.



IS VERY IMPORTANT FOR THE RAIL TO BE FREE OF DIRT BECAUSE IT CAN BE PULLED INTO THE ROLLERS, AND, IN TIME, IT IMPRINTS IN THE PAINT, RESULTING IN DAMAGE OF THE PAINT AND OF THE ROLLERS.

We recommend the following:

- after cca. 10 uses, but no more than a few days, clean the rail with a damp cloth and industrial alcohol or another non-corrosive solution
- if the lift was not used for a long period before starting, clean the rail and remove dust from the rollers
- washing or cleaning of the rack is prohibited, as it has been lubricated with grease at the time of the installation.

If you however have not complied with the above, and if the dust has not imprinted yet, the intervention of an authorized person for cleaning the plastic rollers is necessary.

5.2 BY AUTHORIZED COMPANIES

No further interventions should be required during the warranty period, if using the lift correctly, and maintaining the appropriate cleanliness of the track and observing the annual revisions.

However, if irregularities occur, please contact the company that installed the lift.

After the warranty period, we recommend an annual check of the lift by a company authorized by the manufacturer.

5.3 MAINTENANCE LIST

5.3.1 WEAR PARTS

Wear parts for which we recommend checking are:

- all plastic guide and support rollers
- the sprocket
- other items that would show visible signs of wear.

5.3.2 SAFETY DEVICES

For safety devices and parts, check both their integrity and that of their seals (so as to not be hit accidentally). If any of this safety devices are not working correctly you may call the company that you purchased the stair lift from.

6. WARRANTY AND SERVICE

6.1 WARRANTY

The manufacturer guarantees the proper functioning, operation and maintenance during the period stipulated in the warranty.

The warranty period provided by the manufacturer is 2 years starting from the date of installation of the lift, but not more than 2.1 years after its purchase.

The warranty applies when the installation, use and maintenance of the lift comply with the instructions of use and are performed by trained staff.



IN OTHER CONDITIONS, THIS WARRANTY SHALL NOT BE APPLICABLE.

The following are examples of situations not considered manufacturing defects and not covered by the warranty:

- improper installation, improper use and maintenance;

- minor mechanical deficiencies such as inadequate tightening of nuts, bolts and screws, and them not being secured;
- deficiencies due to negligence, fire, water, natural phenomena or disasters, and defects occurred during transport.

In the event of a failure under warranty, the beneficiary has to inform the company that performed the lift installation to identify the fault. After the fault was identified the manufacturer must be informed by the company that installed the lift.

6.2 SERVICE

The installation, maintenance and repair of stair lifts can be made only by companies authorized to do so by the manufacturer.

After the warranty period, if a service contract is purchased, the authorized company that delivers and installs the stair lift is required to perform maintenance and repair thereof, and to respond to client requests. The name and address of such company shall be specified in Annex 1 of this manual.

Annex 1.

PRODUCT INFORMATION	
Type	
Series	
Date of purchase	
INSTALLER INFORMATION	
Company name	
Contact person	
headquarters	
Phone	
Fax	
E-mail	
BUYER INFORMATION	
Name	
Address	
Phone	
E-mail	