

Pilot
KEEP MOVING

Owner's Manual

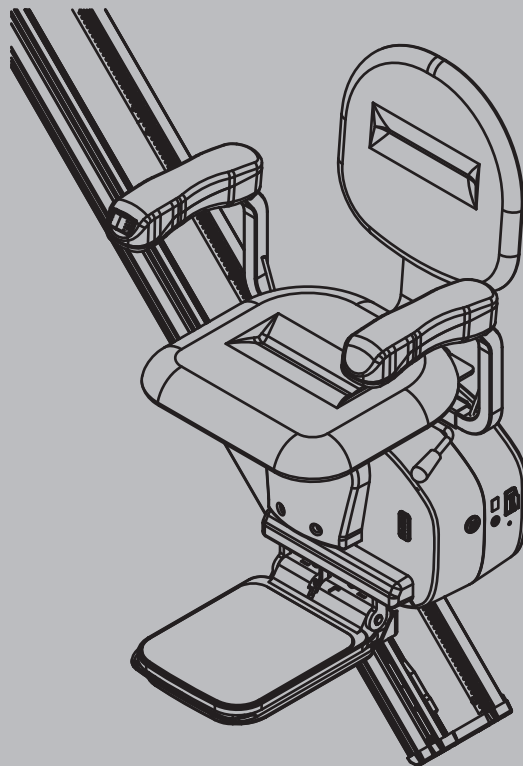

Read this manual before
using the Stairlift and
save for future reference.

This page intentionally left blank.

TABLE OF CONTENTS

0. IEC SYMBOLS	2
1. DANGERS	3
2. WARNINGS	3
3. CAUTIONS	4
4. INTENDED USE	4
5. DESCRIPTION	5
6. SPECIFICATIONS	6
7. OPERATION	8
7.1 Power on the Stairlift.....	8
7.2 Unfolding the Seat and the Footrest	8
7.3 Getting on the Seat.....	9
7.4 Drive the Stairlift.....	10
7.5 Getting off the Seat	10
7.6 Folding up the Footrest and the Seat.....	10
7.7 Remote Controller.....	10
7.8 Hand Winding the Stairlift.....	11
7.9 Recharging the Battery.....	11
8. TROUBLESHOOTING AND MAINTENANCE	12
8.1 Troubleshooting.....	12
8.2 Diagnostic Codes.....	13
8.3 Maintenance.....	14
Warranty	15
Maintenance Record	16

0. IEC SYMBOLS



Caution, Attention or Consult accompanying documents.



Consult Instructions for Use



Alternating Current



Direct Current



Type B Equipment



May contain substances that could be harmful to the environment if disposed of in places (landfills) that are not appropriate according to legislation.



Weight Capacity. DO NOT overload the Stairlift.



1. DANGERS

- The stairlift is designed to carry one person at a time. Do not attempt to carry more than one person.
- Do not allow children to play with the stairlift. It is recommended to remove the key when children are present to prevent unauthorized use.
- Ensure that your clothing is clear of the carriage and rail assemblies before using the stairlift.



2. WARNINGS

- Always fasten seat belt while sitting.
- DO NOT overload the stairlift. The total load limit is 158 kg (350 lbs) @ 45° or 137 kg (300 lbs)@55°. (According to ASME A18.1, no lift should be installed to operate on a greater incline than 45 deg. as measured on the mean.)
- The Battery Charger must only be used in a dry environment.
- Batteries containing in the stairlift are rechargeable and replaceable, but can only be replaced by qualified personnel. DO NOT try to open or replace them by yourself. The used Batteries must be disposed of in the proper manner.

3. CAUTIONS

- Turn off key switch and remove key when the stairlift is not to be used.
- The ON/OFF switch must remain in the ON position to allow the batteries to charge when not in use.
- Maintain the battery in a full charged state for storing. Switch off the On/OFF switch to prevent battery drain. Recharge the battery again monthly.

4. INTENDED USE

The Stair Lift System is a powered patient transport, also commonly known as a Stairway Chairlift, or Stairlift. It is a motorized device intended for medical purposes to assist transfers of patients, or mobility-impaired persons, up and down flights of stairs. This stairlift can only be used on straight staircases inclined between 25°~55°. It is designed to carry one person at a time and the maximum weight capacity is 158kg (350lbs). Any other uses which this stairlift does not intend for may cause serious injury or damage to personal property.

5. DESCRIPTION

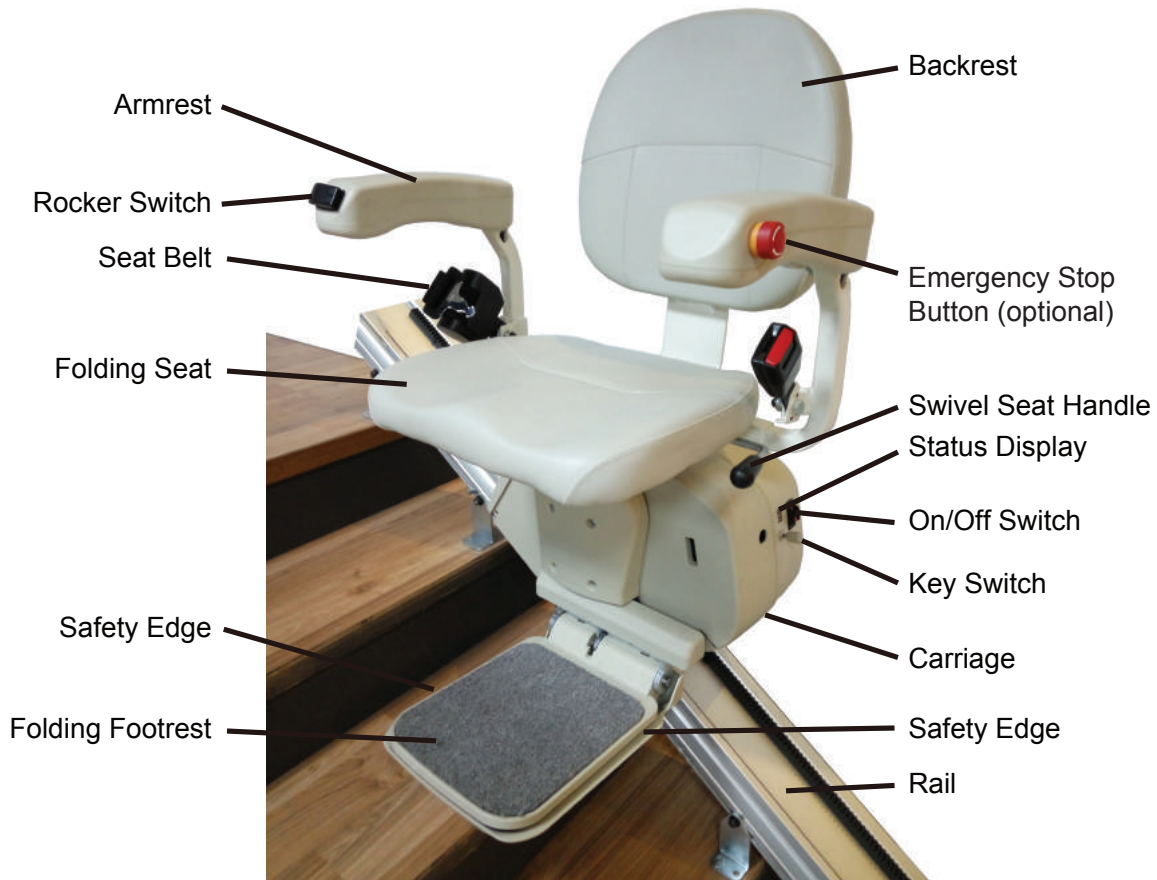

The Stairlift consists of four parts: the carriage, the footrest, the seat, and the rail. The stairlift is powered by the rechargeable batteries inside the carriage. There are safety sensors on upper and lower covers and bottom of footrest. These sensors will stop the unit if any obstruction is detected on the rail or stairway. The footrest, the armrests and the seat can be folded up when not in use to allow more space on the stairway. Pull the swivel handle up to unlock the seat when you reach the top of the stairs. This will allow you to get into or out of the seat at a convenient position. The rail has two charging points at the top and bottom. The batteries will be recharged automatically when the unit stops at these positions.

6. SPECIFICATIONS

Dimensions:

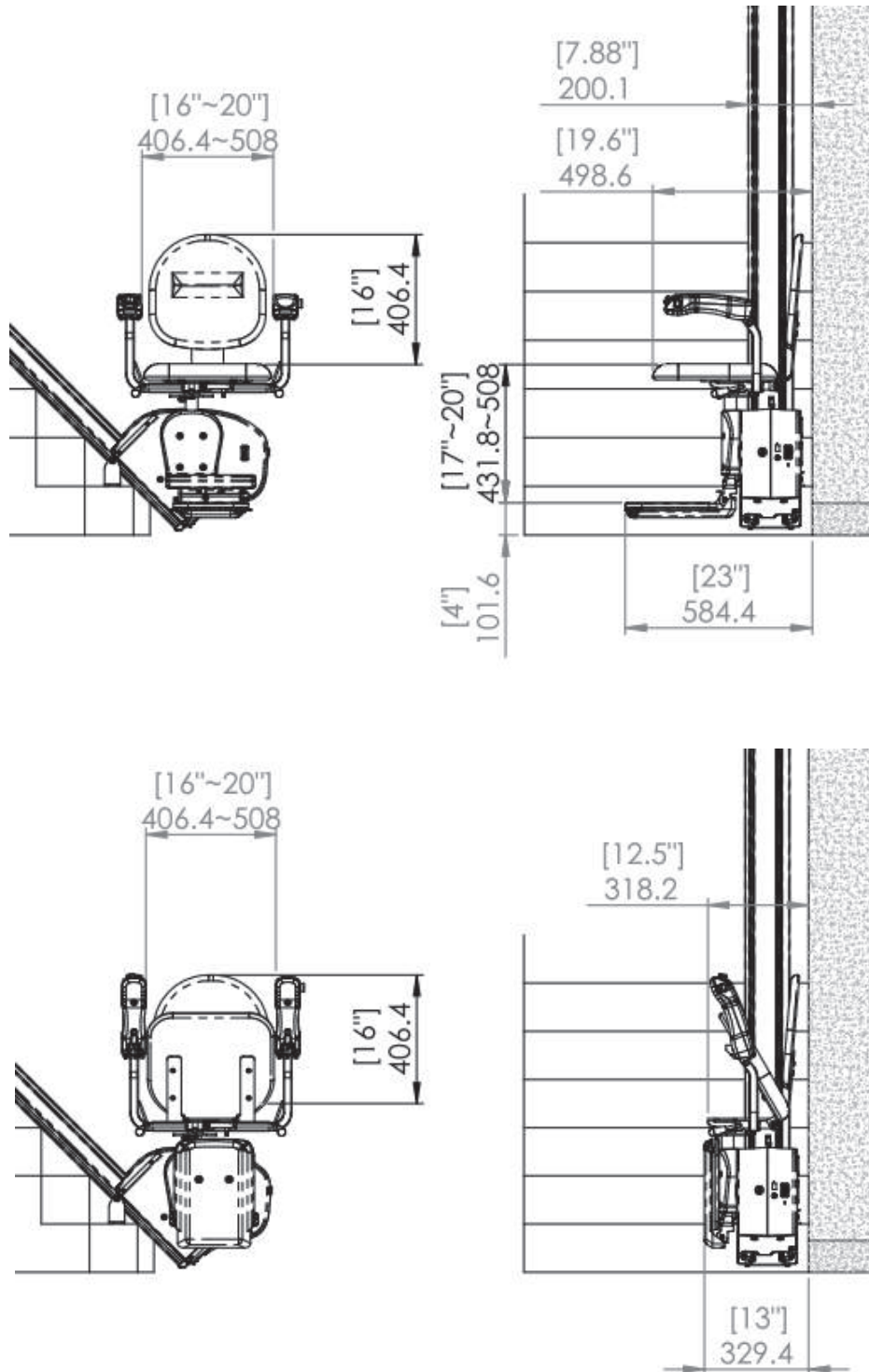

Lighting Requirements - The stairway where the lift is installed shall have a minimum of 50 lux lighting at each landing.



Technical Specs:	
Load Capacity	158kg (350 lbs)@45° or 136kg (300 lbs)@55°
Range of Stair Angle	25°~55° Note: According to ASME A18.1, no lift should be installed to operate on a greater incline than 45 deg. as measured on the mean.
Travel Speed	6 m/min. (20 ft/min)
Maximum Travel	9.75m (32 ft)
Drive System	Rack and Pinion
Operator Control	Constant-pressure type (rocker switch and remote controller)
Operating Voltages	24VDC rechargeable batteries
Motor	1/2 HP, 24VDC
Brake (Optional)	Electromagnetic brake
Charging	On the top or bottom stop of the rail. Input: 115/230VAC, 50/60Hz. Output: 24V  2A
Operating Ambient Temperature (Humidity)	5°C ~ 40°C (41°F ~ 104°F) (up to 95% non-condensing) (up to 2,000m in altitude)
Storage/ Transport Temperature (Humidity)	-10°C ~ 60°C (14°F ~ 140°F) (up to 95% non-condensing)

7. OPERATION

WARNING

- Ensure the stairway is free from obstacles before operate the stairlift.

7.1 Power on the Stairlift

1. Switch the ON / OFF switch to the ON position. (Under regular operating conditions, the ON / OFF switch should remain ON at all times to allow the batteries to recharge when not in use).
2. Insert the key and turn a quarter turn clockwise to the ON position. The status display will indicate . If the display is not indicating , please check the “Diagnostics” section on pages 11 and 15.

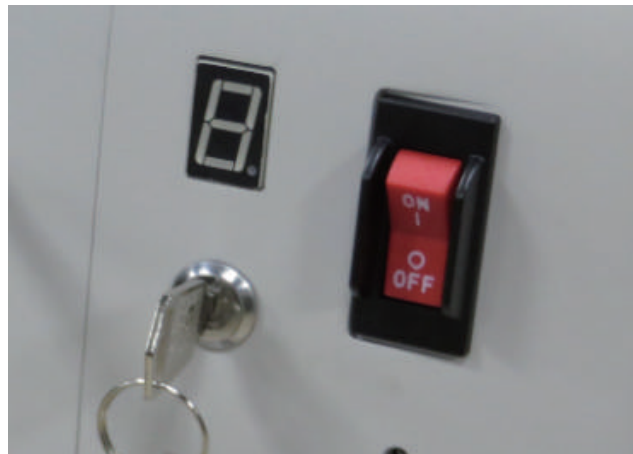

7.2 Unfolding the Seat and the Footrest

1. Fold down the footrest.
2. Fold down the seat.
3. Fold down the two armrests.

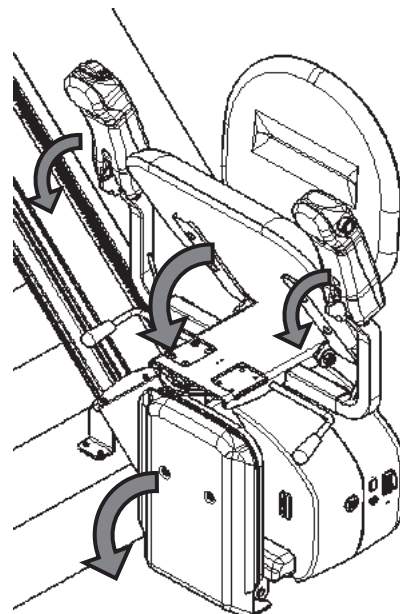

7.3 Getting on the Seat

1. Pull up the swivel handle to rotate the seat. (only upstairs)



2. Push down the swivel handle to lock the seat at 70° facing the staircase landing. (only upstairs)

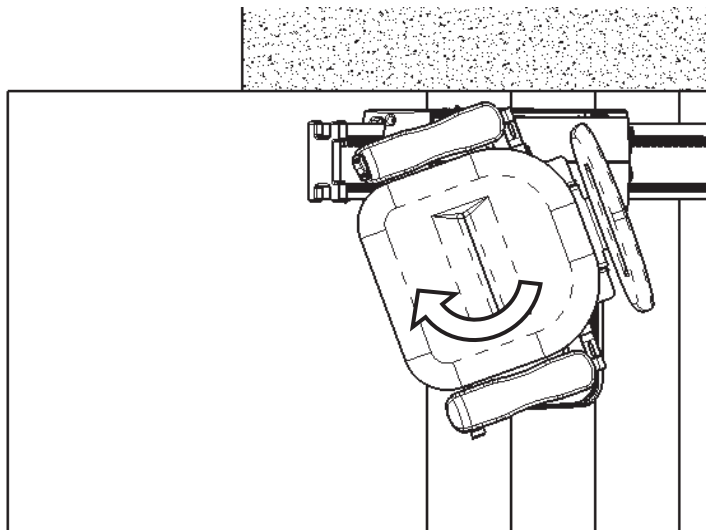

WARNING

- Make sure the seat is locked before getting on and off the stairlift.
- Avoid pressing on the rocker switch while getting on and off.

3. Sit down on the seat with your back against the backrest. Fasten the seat belt.

4. Pull up the swivel handle and then rotate the seat back to be parallel to the rail.
(only upstairs) Push down the swivel handle to lock the seat.
5. Put your feet on the footrest and place your arms on the armrests.

7.4 Driving the Stairlift

Press the UP/DOWN rocker switch located on the front of the right armrest to move the stairlift in the desired direction. The stairlift will stop automatically when it reaches the end of rail or the rocker switch is released.

7.5 Getting off the Seat

Swivel the seat as required. Unfasten the seat belt and get off the seat.

WARNING

- Make sure the seat is locked before getting on and off the stairlift.
- Avoid pressing on the rocker switch while getting on and off.

7.6 Folding up the Footrest and the Seat

The footrest, the armrests and the seat can be folded up when not in use to allow more space on the stairway.

7.7 Remote Controller

There are two remote controllers allow you to “call” or “send” the stairlift. Point the remote controller at the unit and press the button in the desired direction.



Note: The remote will not operate if the seat has been turned or the armrest on the downstairs side has been folded up.

7.8 Hand Winding the Stairlift

The hand winding feature should only be used to move the stairlift when there is a power failure.

1. Turn off the ON/OFF switch.
2. Remove the rubber cover on the left side of the carriage, and then push the brake lever upward to release the brake if required.
3. Remove the rubber cover next to the key switch. Insert the hand crank onto the motor spindle.
4. Turn the hand crank counter-clockwise to lower the stairlift.
5. Remove the hand crank and push the brake lever downward to engage the brake if required.



WARNING

- Remove the hand crank before turn on the power.

7.9 RECHARGING THE BATTERY





The charging points are located at top and down of the rail. The stairlift will stop automatically at these points. The battery recharging will not start if the ON/OFF switch is turned off.



8. TROUBLESHOOTING AND MAINTENANCE

8.1 Troubleshooting

Check the basic items listed below if your stairlift does not work properly.

SYMPTOM	PROBABLE CAUSE	SOLUTION
Stairlift will not move. The status display is off.	<ol style="list-style-type: none"> 1. The ON/OFF switch is OFF. 2. The key switch is turned off. 	<ol style="list-style-type: none"> 1. Turn on the ON/OFF switch and the key switch.
Stairlift will not move. The status display indicates  .	<ol style="list-style-type: none"> 1. The swivel seat is not locked in the right position. 2. The armrest is not folded down. 3. The Emergency Stop Button has been pressed. 4. The final limit switch is activated. 5. The over speed governor (optional) is activated. 	<ol style="list-style-type: none"> 1. Rotate and lock the seat in the right position. 2. Fold down the armrest. 3. Release the Emergency Stop Button. 4. Contact your authorized dealer. 5. Contact your authorized dealer.
Stairlift will not move. The status display indicates  or  .	<ol style="list-style-type: none"> 1. The safety sensor is activated. 	<ol style="list-style-type: none"> 1. Remove the obstacle on the rail or staircase.
Stairlift moves at half speed. The status display indicates  .	<ol style="list-style-type: none"> 1. The battery voltage is low. 	<ol style="list-style-type: none"> 1. Move the stairlift to the downstairs end and recharge the battery. 2. Contact your authorized dealer if the battery cannot be recharged.
Stairlift emits beeping sound at the end of the rail. The status display indicates  .	<ol style="list-style-type: none"> 1. The batteries are not charging. 	<ol style="list-style-type: none"> 1. Check that the charger is plugged in and charging.

Contact your authorized dealer if the stairlift still does not work after the basic items have been checked.

WARNING

- Never try to repair the stairlift by yourself.

8.2 Diagnostic Codes

Refer to the following table to help diagnose and correct any faults.

Code	Status/Fault	Recommended Corrective Action
	No display.	Check that the key switch and ON/OFF switch are turned on.
-	The stairlift is ready to use.	No action required.
U	<ol style="list-style-type: none"> 1. The swivel seat switch is activated. 2. The armrest switch is activated. 3. The Emergency Stop Button has been pressed. 4. The final limit switch is activated. 5. The over speed governor (optional) is activated. 	<ol style="list-style-type: none"> 1. Rotate and lock the seat in the right position. 2. Fold down the armrest. 3. Release the Emergency Stop Button. 4. Contact your authorized dealer. 5. Contact your authorized dealer.
2	Batteries are not charging.	Check that the charger is plugged in and charging.
3	Upper limit switch is activated.	You have reached the upper limit. Run the unit in the down direction.
4	Safety sensor in up direction is activated.	Remove any obstacle that may have activated the switch.
5	Lower limit switch is activated.	You have reached the lower limit. Run the unit in the up direction.
6	Safety sensor in down direction is activated.	Remove any obstacle that may have activated the switch.
L	Motor current limit is exceeded	Contact your authorized dealer.
E	Main control board error.	Switch off the key switch for 30 seconds and then switch on again.
P	Rocker switch or remote controller is activated when power on.	Release the switch or button. No action required.
9	Motor brake is not engaged.	Push down the lever of motor brake.
U	The batteries voltage is too high.	Switch off the key switch for 30 seconds and then switch on again.
n	The batteries voltage is too low.	Move the stairlift to the downstairs end and recharge the battery. Contact your authorized dealer if the battery cannot be recharged.

8.3 Maintenance

You can clean the seat with a soft, damp cloth and possibly a mild detergent. The dust particles can be removed using the vacuum cleaner. In addition to cleaning the stairlift, regular maintenance is needed to keep your stairlift working properly. We recommend to follow the maintenance schedule below to ensure your stairlift will stay in optimal condition

Verification by owner	Frequency
Check that the swivel seat switch and the armrest switch are working. Ensure the unit will not move until the swivel seat is locked in the right position and the armrests are folded down.	Every 3 months
Check that the footrest and carriage sensors are working. Ensure the unit stops when it contacts an obstacle.	Every 3 months
Check that the emergency stop button is working. (optional) Ensure the unit stops immediately when the button is pressed.	Every 3 months
Verification by technician	Frequency
Check the operation of the limit switches. Ensure the unit stops at the required position at the top and bottom of the stairway.	Every 6 months
Check the operation of the over speed governor.(optional)	Every 6 months
Check the final stopping limit switch	Every 6 months
Lubricate the unit.	As required

Warranty

We warrant the Stairlift to be free from defective workmanship and materials for a period of 5 year on the motor & gear box and 2 years for other parts from the date of purchase. The rechargeable battery is warranted for 90 days from date of purchase. Check with your dealer for more details. This warranty is limited to the original purchaser of the Stairlift. Any defective part or assembly will be repaired or replaced, at the sole discretion and determination of the manufacturer, if the unit has been properly operated during the warranty period. Normal maintenance items and disposable components are not covered by this warranty. Shipping charges, if any, shall be paid by the purchaser.

Note: There is no other express warranty. Implied warranties, including those of merchantability and fitness for a particular purpose, are limited to the duration of the express limited warranty and to the extent permitted by law and all implied warranties are excluded. This warranty does not cover providing a loaner Stairlift, compensating for costs incurred for Stairlift rental, or labor costs incurred in repairing or replacing defective part(s)

INSTALLATION RECORDS

Customer Name: _____

Dealer Name: _____

Dealer Address: _____

Dealer TEL. No.: _____

Date of Installation: _____

Serial No. / Job No.: _____

With you for life



MERITS HEALTH PRODUCTS, INC.

www.meritsusa.com 730 N.E. 19th Place, Cape Coral, FL 33909
TEL:1-800-963-7487, 1-239-772-0579 FAX:1-239-574-2661